

SMART ENERGY EFFICIENT HOME AUTOMATION SYSTEM USING IOT

#1 R. Bhargav, M.Tech Student,
#2 Dr. S. Nanda Kishore, Associate Professor,
#3 Dr. B.D Venkataramana Reddy, Professor, Department of ECE,

Viswam Engineering College, Angallu, Ap.

Abstract: A smart, energy-efficient home control system that saves energy and simplifies user life is the focus of this study, which is based on the Internet of Things (IoT). The technology makes use of cloud computing, smart sensors, and actuators to monitor and control household appliances in real-time. Automation, made possible by the Internet of Things, reduces energy waste by responding to human behavior and environmental factors. Machine learning systems aim to predict future energy consumption in an effort to improve efficiency. By enabling remote access through mobile apps, the solution provides you freedom and security. People can save energy with the help of smart meters because they provide immediate feedback. If we want to stay alive, we have to start using renewable energy. The home's automated lighting, climate control, and security systems all contribute to its lower energy consumption. The study examines the cost, scalability, and interoperability of IoT devices. The goal of implementing cybersecurity measures is to prevent unauthorized individuals from gaining access. By adjusting to various living conditions, the proposed approach enhances energy consumption. Energy savings and an improved user experience are demonstrated through case studies. In order to enhance optimization, future research will concentrate on new AI advancements. The findings demonstrate the impact of the Internet of Things on sustainable smart home solutions.

Keywords: Smart Home, IoT, Energy Efficiency, Home Automation, Machine Learning, Smart Sensors, Renewable Energy, Cybersecurity, Smart Meters, Remote Access.

This is an open-access article distributed under the terms of the Creative Commons Attribution 4.0 International License (CC BY 4.0), which permits unrestricted use, distribution, and reproduction in any medium, provided the original author(s) and the source are properly cited.

1. Introduction

Rapid expansion characterizes the IoT. Because of this, home technology has undergone a dramatic shift, paving the way for more convenient and environmentally friendly smart energy solutions. To monitor, control, and enhance a house's energy consumption, smart, energy-efficient home management systems employ Internet of Things (IoT) technologies. With the increasing need for smart homes and energy efficiency, these systems automate the maintenance of household appliances, reducing unnecessary energy consumption and enhancing user comfort.

Smart sensors, actuators, and cloud computing enable Internet of Things (IoT) home automation systems to obtain real-time data on energy consumption. These systems adapt the temperature, lighting, and ventilation to the current occupancy and environmental conditions of the building. By anticipating energy consumption and automating processes accordingly, machine learning algorithms

improve efficiency. Homeowners can enjoy greater independence and better control over their energy consumption by using smartphone apps to remotely monitor and control their appliances from any location.

To reduce their impact on traditional power grids, smart home systems built on the Internet of Things make use of renewable energy sources, such as solar electricity. One of the key advantages is this. People may make informed decisions about their energy consumption thanks to smart meters, which provide real-time data on electricity usage. Not only do smart homes save energy, but they're also secure and simple to operate. Automated locks, monitoring systems, and AI-generated alarms make the entire house safer.

Interoperability issues, hacking concerns, and installation costs need to be addressed before it can be extensively used, despite its many benefits. Streamlined communication protocols, robust encryption, and more affordable technologies can all

enhance the development of smart, energy-efficient home automation. Improved security features, broader integration of renewable energy sources, and predictive analytics driven by artificial intelligence will characterize the future of home automation as the Internet of Things (IoT) develops further. As a result, houses will become more environmentally friendly and intelligent.

2. Literature Survey

Pathare & Sethi (2024) – The Internet of Things (IoT) may improve smart homes' control of renewable energy sources is the focus of this research. One technique to deliver power more effectively is through net metering, which is lauded. Finding ways to save energy through automation is the main emphasis of the study. The topic of connecting to smart grids is being discussed. The report argues in favor of energy usage that benefits the environment.

Pawar et al. (2024) - Here we take a look at solar-powered smart home automation systems. It demonstrates the ways in which household systems have been enhanced to reduce energy consumption. The study delves into the potential applications of AI and IoT. We examine potential future directions and issues. Environmentally friendly lifestyles are promoted.

Oseiwe & Ajadalu (2024) - In order to determine how smart houses may most effectively use energy, this study used reinforcement learning. This article explores potential energy-saving applications of the Internet of Things. Included in the research are adaptive control strategies. Making real-time adjustments to energy use is now within reach, all thanks to machine learning. Energy expenses have dropped significantly, according to the results.

Abbas et al. (2024) - This study demonstrates an automated approach to household energy management. Controlling intelligent machinery is a major focus. Productivity and oversight are both enhanced by incorporating IoT. Sustainability and cost reduction are given top billing in the study. Discussions are circulating regarding the impending actions to enhance smart energy systems.

Garg et al. (2023) - In this article, we will examine the ways in which building automation may manage energy consumption and occupant comfort. Various strategies for maintaining control over green building practices are examined. There is a lot of focus on HVAC, lighting, and security in the research. We examine ways to make energy use more efficient. Future directions in sustainable robotics are proposed.

Kalogridis et al. (2021) - Concerns about personal data security raised by smart meters are the focus of this article. We address the issue of untraceable appliance load profiles. A variety of data encryption methods are examined. Eliminating the practice of unlawfully monitoring people's energy consumption is the primary objective of the study. How smart grids might compromise people's personal information is laid bare.

Sou et al. (2021) - In this study, mixed-integer linear programming is used to schedule smart home appliances. It places an emphasis on saving money and maximizing energy efficiency. The focus of the project is dynamic load balancing. Scheduling that is driven by AI maximizes power efficiency. Smart homes benefit from this method's improved control.

Lee et al. (2021) - How to manage a smart house via the cloud is demonstrated in this study. For the purpose of resource distribution, it has a community framework. By incorporating IoT, real-time tracking is enhanced. Priorities for the study include energy efficiency and safety. Many are discussing the practical applications of smart cities.

Kim et al. (2020) - In this research, we take a look at energy-tracking home display devices. It raises consciousness about power consumption. Using energy more effectively becomes easier with real-time feedback. Users can more easily participate thanks to data analytics and the Internet of Things. The report recommends the usage of sustainable energy methods.

Son et al. (2020) - The focus of this research is a home energy control system that makes use of electricity lines. It has energy-saving smart tools. Power costs are reduced by the system. It is possible to optimize energy use using real-time tracking. Analyzed are real-life smart home apps.

Kushiro et al. (2020) - This research is part of a larger effort to develop a home gateway controller with integrated features. It simplifies the process of installing energy management technologies in residential areas. Energy management on the demand side is made easier by the system. Internet of Things tracking improves efficiency. Major advancements in home technology are the topic of much discussion.

Hernandez et al. (2020) - Better house illumination is the focus of this research, which employs neural networks. Artificial intelligence (AI) based regulations improve energy efficiency. The adaptive lighting methods are the main focus of the study. Smart devices automatically adjust the lighting. Better energy economy is the implication of the results.

Han et al. (2020) - This study examines the energy consumption of several household appliances.

Environmentally conscious houses should have an energy control system. Optimisation becomes much simpler with real-time tracking. Artificial intelligence can help things operate more smoothly, according to the study. More emphasis is placed on energy-efficient smart solutions.

Ramlee et al. (2020) - A home control system's planning and construction process is detailed in this paper. You may control your appliances from a distance using technologies that are based on the Internet of Things. The study delves into the topic of cost-cutting technology. Two crucial components are energy management and security. Applications for smart homes are examined.

Shakeri et al. (2020) - Smart energy management at home is demonstrated in this study. We improve our strategies to response to demand. Saving energy is a byproduct of AI-controlled automation. How to link up with the smart grid is the focus of the research. What is being advocated for are renewable energy sources.

Kumar & Kumar (2020) - Specifically, this research examines the IoT. As an example of how home technology can improve efficiency, it is provided. Real-time energy consumption tracking becomes much simpler with IoT connectivity. Analyzing electricity utilization can be made easier with the help of artificial intelligence, according to the study. There has been much discussion over potential future applications of novel concepts in energy control.

Alam et al. (2020) - In this paper, we'll trace the evolution of smart home gadgets. Concepts from the past, present, and future are juxtaposed in it. The most recent developments in AI, robotics, and the IoT are examined. Issues that arise while attempting to implement smart home technologies are examined. More avenues for investigation into the topic are proposed by the study.

Khan & Khan (2020) - Machine learning approaches to cloud security are discussed in this review. It discusses the ways in which AI can aid in the detection of dangers. The research investigates issues related to hacking in cloud environments. There is an examination of various approaches to enhancing privacy. Topics covered include smart homes and the Internet of Things (IoT).

Pal et al. (2020) - Care for the elderly is one area that the article examines in relation to the Internet of Things. Smart homes for the elderly are receiving a lot of focus. People are safer and healthier with AI-enhanced surveillance. You can monitor your vitals in real time with wearable tech. Evidence from studies supports independent living choices.

Siano & De Marco (2020) - The question this poll sets out to answer. Discussions regarding distributed ledger technology have taken place in regional energy markets. The advantages of transparency and security are highlighted.

Practical applications of blockchain technology are the focus of the research. Areas for future research have been proposed.

Zhou et al. (2020) - How smart homes may manage their energy consumption is the topic of this essay. Various configurations and scheduling strategies are examined. Increased productivity is a direct result of AI-driven automation. The research investigates potential methods of real-time monitoring. Methods to reduce energy consumption are emphasized.

Gungor et al. (2020) - Investigating smart grid communication is the goal of this study. It discusses updated regulations for more equitable distribution of power. Grid management is improved with the addition of IoT. The report examines concerns related to hacking. Future developments in smart grid technologies are examined.

Li & Wen (2020) - The study's core focus is on smart grid demand response management. Methods for optimizing energy usage are covered in it. The development of AI-powered robots is a topic of active study. Possible cost-cutting measures are highlighted in the analysis. Potentially more effective demand response strategies have been proposed.

Yan et al. (2020) - Methods of smart grid communication are the focus of this survey. Network requirements and issues are discussed. In this work, we explore the potential of the Internet of Things (IoT) for energy distribution. What kinds of security threats exist and how to mitigate them are determined. Improving smart grid connections is on the horizon according to certain recommendations.

3. Proposed System

The suggested system makes use of communication technologies like Wi-Fi, Zigbee, and Bluetooth to make it easier for a central control unit to communicate with smart devices. Voice assistants like Google Assistant and Amazon Alexa make it easy to access and control the system from any smartphone. The system analyzes energy patterns and forecasts optimal energy consumption using machine learning methods. If a user's device has an electrical problem, unusually high or low power consumption, or anything else out of the ordinary, they will be notified immediately. Thanks to their autonomous scheduling features, machines can run during the times when they use the least amount of energy. The safety,

functionality, and environmental friendliness of smart homes are all enhanced by applying this predictive strategy. Reduced energy costs and carbon emissions are only two of the many advantages offered by the technology. By optimizing energy use, users can greatly decrease waste and help to environmental protection thanks to sophisticated automation. Installing a home security system with features like smart door locks and remote monitoring can greatly increase your peace of mind. Combining renewable energy sources, like solar panels, increases the use of green energy. Using the Internet of Things (IoT), this home automation system offers a smarter, more efficient, and long-lasting way to control how much energy a household uses.

Benefits:

- **Energy Conservation** – In response to external weather conditions and occupancy levels, the system can manage the building's lighting, climate control, and appliance power use to reduce energy consumption.
- **Cost Savings** – By utilizing automated scheduling and smart energy management, homeowners can drastically decrease their monthly power expenditures by cutting down on wasteful energy consumption.
- **Remote Monitoring & Control** – It can be helpful for people to be able to control and monitor their home appliances from anywhere using apps or voice assistants on their smartphones.

4. Hardware Node Mcu

When it comes to the Internet of Things, NodeMCU is an affordable, open-source option. Among these features is a Wi-Fi module. Tensilica Xtensa L106, a

- **Enhanced Security** – Among the components of a smart home automation system are motion detectors, security cameras, and smart locks. With these capabilities, home security is taken to the next level with real-time warnings and remote access.
- **Predictive Maintenance** – In order to avoid equipment failure and repair costs, the Internet of Things (IoT) makes available sensors that can identify electrical defects and unusual energy trends.
- **Environmental Sustainability** – Through the utilization of renewable energy sources and the reduction of energy waste, the system encourages the adoption of sustainable and eco-friendly lifestyles (e.g., solar panels).
- **User Customization & Automation** – Reduced energy costs and improved living conditions are possible outcomes of homeowners' capacity to set up their equipment to follow predefined patterns.
- **Smart Data Analytics** – Customers may have a better grasp of their energy use habits with the help of data powered by AI, allowing them to make more informed decisions about how to make their homes more energy efficient.
- **Improved Home Comfort** – Automated climate control responds to changes in the weather by adjusting the temperature and humidity, creating a comfortable environment with little energy consumption.
- **Integration with Smart Grid** – Optimal distribution of energy can be achieved by regulating usage during peak and off-peak hours when combined with smart infrastructure.

32-bit central processing unit, has a low-noise receiver, filters, power control modules, and amplifiers. It makes use of Lua.

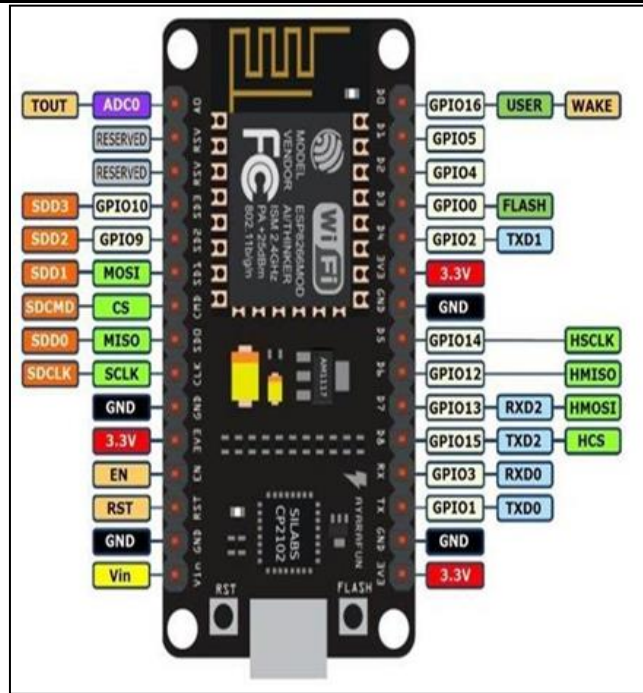

Fig 1: Node MCU Advantages of NodeMCU

1. Low power consumption.
2. Inbuilt Wi-Fi module
3. Low cost.

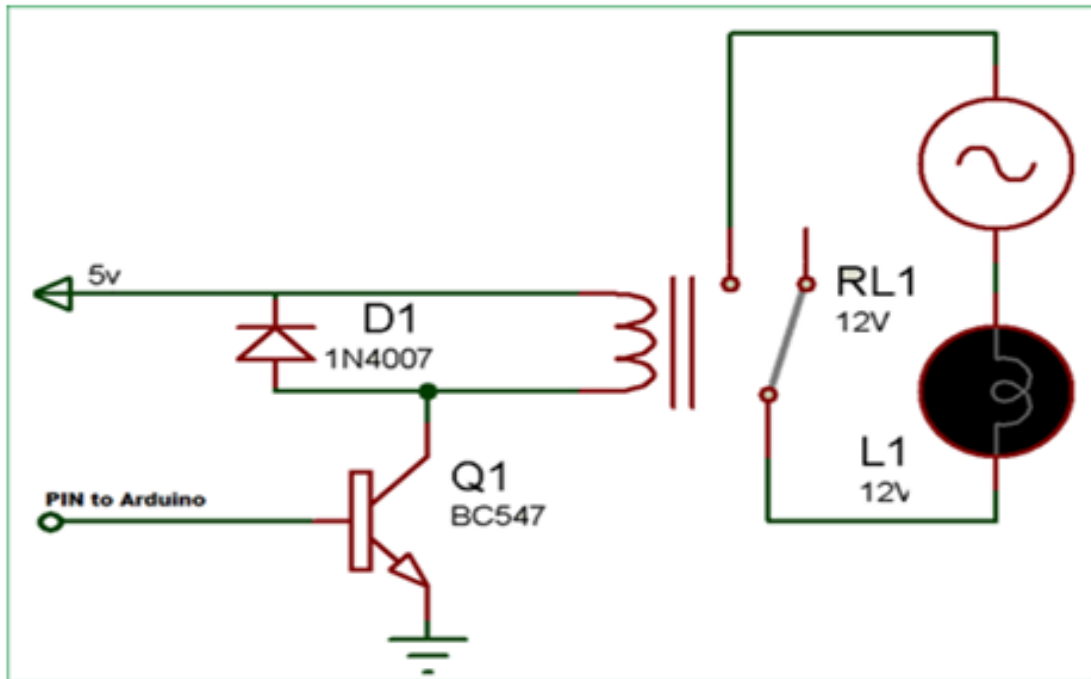

Fig 2: Relay

5. Software

Google assistant

It is possible to build a synthetic voice assistant using software that leverages Google's artificial intelligence. In reaction to the sound you make, it makes noises. A mobile device's usefulness and usability are greatly

improved by this. Spelling out "Ok Google" is all it takes to turn it on.

Thanks to this app, we can control our home appliances from anywhere by just speaking to them.



Fig 3: Virtual Assistant

Blynk

In addition to being compatible with phones, this software can control devices via Wi-Fi. The TCP/IP system is in charge of its functionality. Numerous Internet of Things (IoT) applications are within the

software's capabilities. In order to control our home appliances, this application will create virtual switches for our project.

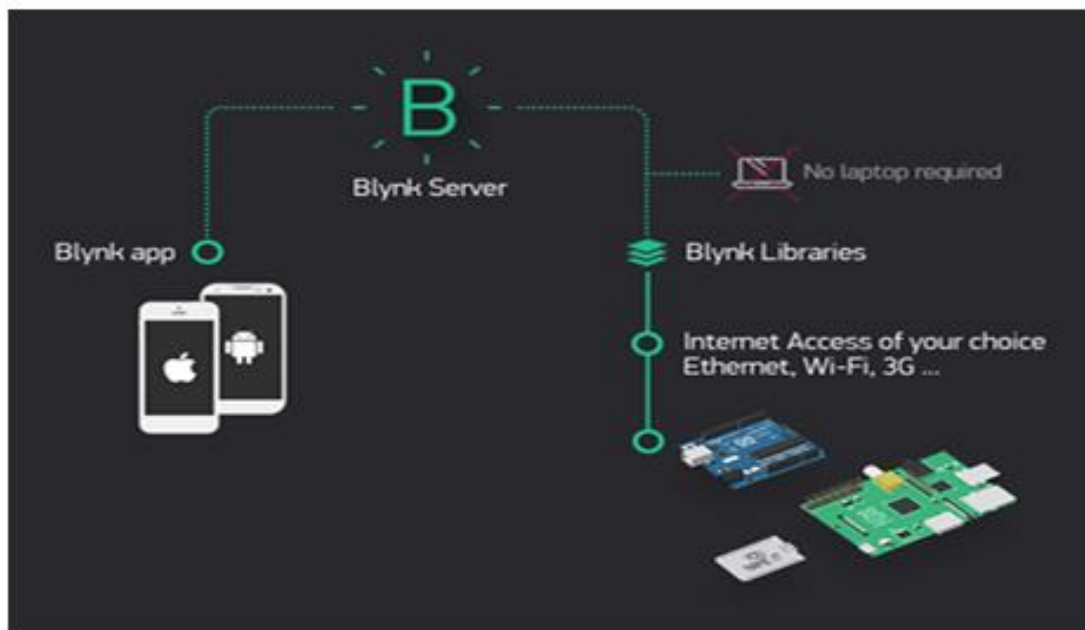

Fig 4: Blynk Server

Relay channel module

Relays, which are valves, are required by a great number of power-hungry devices. Microcontrollers are able to manage it. In order to power the devices, the NodeMCU receives high-voltage signals and activates the inductor. It can't activate even when exposed to very little power, therefore it stays dormant.

To put it simply, "If This Then That" defines the phrase totally. Thanks to this, the Blynk app and the Google Assistant can have a two-way conversation. Creating an applet that pairs Blynk with Google Assistant is a top priority. When we speak the voice instructions needed to control our home appliances, this applet activates and tells Blynk to reply. To

access Google Assistant, you need a Google account, which is required to view this website.

Arduino IDE

Using this tool, programming circuits that are compatible with Arduino becomes much easier. Code can be written in C, C++, or Java. Incorporating the Blynk app's registration code into the NodeMCU board's code is essential.

6. Working and Result

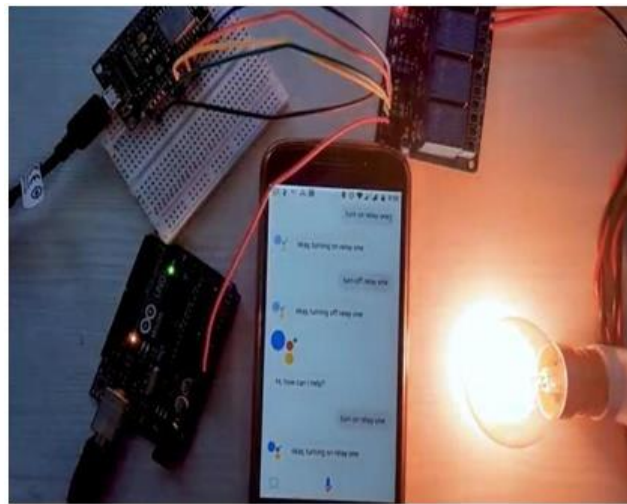

Fig 5: Working Connection

7. Conclusion

To ease daily living, save costs, and optimize energy efficiency, an Internet of Things (IoT) based smart home administration system is necessary. Using cloud computing, AI-driven automation, and smart sensors, the system can manage and keep tabs on home appliances in real time. Features like predictive maintenance, automated scheduling, and remote access ensure energy efficiency and waste reduction. In addition to improving the user experience and streamlining and intelligently managing house administration, the Internet of Things enables a seamless device connection.

Future Scope:

The recent advancements in artificial intelligence (AI), big data analytics, and the smart grid have greatly improved the chances of success for an IoT-based, energy-efficient home control system. There is a widespread worry about the environment, therefore home automation systems built on the internet of things (IoT) will use machine learning to cut power use. Home appliances will soon be able to adjust to user habits, environmental factors, and energy consumption thanks to self-learning technologies.

After we've built a prototype and installed all the required components, we can utilize Google Assistant to operate our home appliances by sending voice instructions through the NodeMCU. The Blynk app can be linked to IFTTT in order to accomplish this.

Here, the Internet of Things (IoT) serves as the central focus. With the help of NodeMCU, this smart home automation system allows users to command their appliances simply by speaking to them. It is smart and it uses less energy.

Environmentalists would appreciate this approach because it prioritizes renewable energy sources and cuts down on carbon emissions. By allowing demand-based energy use, smart grid integration directly contributes to reducing strain on the power system. Modern technological security solutions, such as remote monitoring and smart locks, make homes safer. Smarter, more efficient, and less harmful to the environment will characterize future home control systems built on the IoT.

There will be less energy waste and lower electricity costs as a result of enhanced operational efficiency. The speed and dependability of smart home automation will rise as 5G connections and edge computing keep speeding up. Automated systems will improve areas like heating, ventilation, and lighting as well as security in the future by making it easy to link all Internet of Things devices. Solar panels and smart grids are two examples of renewable energy sources that can enhance home

sustainability. Energy generation, storage, and consumption may all be made more efficient with the help of these technologies. Integrating blockchain technology and improving security measures to

safeguard IoT-enabled smart homes from cyber attacks is vital for protecting user privacy and ensuring the system runs properly.

References

1. Pathare, A. A., & Sethi, D. (2024). Development of IoT-enabled solutions for renewable energy generation and net-metering control for efficient smart home. *Discover Internet of Things*, 4(1), 11.
2. Pawar, S. B., Abrol, P., Mishra, A., & Adgurwar, S. (2024). Solar empowerment: A critical review of intelligent home automation technologies. *Journal of Nuclear Engineering & Technology*, 14(1), 25–31.
3. Oseiwe, S., & Ajadalu, A. (2024). Optimizing energy efficiency in smart home automation through reinforcement learning and IoT. *Asian Journal of Research in Computer Science*, 17(11), 9–24.
4. Abbas, H., Ajaz, N. S., Jayaram, N., Thara, S., & Thomas, T. (2024). Energy management system with home automation. *Journal of Energy, Environment & Carbon Credits*, 14(1), 1–10.
5. Garg, Q., Tang, S., Hao, J., Di Sarno, L., Wu, G., & Ren, S. (2023). Building automation systems for energy and comfort management in green buildings: a critical review and future directions. *Renewable and Sustainable Energy Reviews*, 179, 113301.
6. Kalogridis, G., Efthymiou, C., Denic, S. Z., Lewis, T. A., & Cepin, M. (2021). Privacy for smart meters: Towards undetectable appliance load signatures. In *Proceedings of the First IEEE International Conference on Smart Grid Communications* (pp. 232–237).
7. Sou, K. C., Weimer, J., Sandberg, H., & Johansson, K. H. (2021). Scheduling smart home appliances using mixed integer linear programming. In *Proceedings of the 50th IEEE Conference on Decision and Control and European Control Conference (CDC-ECC)* (pp. 5144–5149).
8. Lee, Y. T., Hsiao, W. H., Huang, C. M., & Chou, S. C. T. (2021). An integrated cloud-based smart home management system with community hierarchy. *IEEE Transactions on Consumer Electronics*, 62(1), 1–9.
9. Kim, D. S., Son, S. Y., & Lee, J. (2020). Developments of the in-home display systems for residential energy monitoring. *IEEE Transactions on Consumer Electronics*, 59(3), 492–498.
10. Son, Y. S., Pulkkinen, T., Moon, K. D., & Kim, C. (2020). Home energy management system based on power line communication. *IEEE Transactions on Consumer Electronics*, 56(3), 1380–1386.
11. Kushiro, N., Suzuki, S., Nakata, M., Takahara, H., & Inoue, M. (2020). Integrated residential gateway controller for home energy management system. *IEEE Transactions on Consumer Electronics*, 49(3), 629–636.
12. Hernandez, S., Romero, R., & Giral, D. (2020). Optimization of the use of residential lighting with neural network. In *International Conference on Computational Intelligence and Software Engineering (CiSE)* (pp. 1–5).
13. Han, J., Choi, C. S., Park, W. K., & Lee, I. (2020). Green home energy management system through comparison of energy usage between the same kinds of home appliances. *IEEE Transactions on Consumer Electronics*, 59(3), 402–408.
14. Ramlee, R. A., Leong, M. C., & Ismail, M. A. (2020). Design and development of home automation system. In *Proceedings of the 2013 International Conference on Electrical, Electronics and System Engineering (ICEESE)* (pp. 43–48).
15. Shakeri, M., Shayestegan, M., Abunima, H., Reza, S. S., Akhtaruzzaman, M., Alamoud, A. R. M., & Amin, N. (2020). An intelligent system architecture in home energy management systems (HEMS) for efficient demand response in smart grid. *Energy and Buildings*, 138, 154–164.
16. Kumar, N. M., & Kumar, J. S. (2020). Internet of Things based smart energy management: A survey. *International Journal of Applied Engineering Research*, 15(1), 1–8.
17. Alam, M. R., Reaz, M. B. I., & Ali, M. A. M. (2020). A review of smart homes—Past, present, and future. *IEEE Transactions on Systems, Man, and Cybernetics: Systems*, 42(6), 1190–1203.
18. Khan, M. A., & Khan, S. (2020). A review of machine learning algorithms for cloud

- computing security. *International Journal of Computer Applications*, 97(7), 1–9.
19. Pal, D., Funilkul, S., Charoenkitkarn, N., & Kanthamanon, P. (2020). Internet-of-Things and smart homes for elderly healthcare: An end user perspective. *IEEE Access*, 6, 10483–10496.
 20. Siano, P., & De Marco, G. (2020). A survey and evaluation of the potentials of distributed ledger technology for peer-to-peer transactive energy exchanges in local energy markets. *IEEE Systems Journal*, 14(4), 4948–4959.
 21. Zhou, B., Li, W., Chan, K. W., Cao, Y., Kuang, Y., Liu, X., & Wang, X. (2020). Smart home energy management systems: Concept, configurations, and scheduling strategies. *Renewable and Sustainable Energy Reviews*, 61, 30–40.
 22. Gungor, V. C., Sahin, D., Kocak, T., Ergut, S., Buccella, C., Cecati, C., & Hancke, G. P. (2020). Smart grid technologies: Communication technologies and standards. *IEEE Transactions on Industrial Informatics*, 7(4), 529–539.
 23. Li, H., & Wen, F. (2020). A review of demand response management: From the perspective of smart grid. *Electric Power Components and Systems*, 42(3–4), 279–288.
 24. Yan, Q., Qian, Y., Sharif, H., & Tipper, D. (2020). A survey on smart grid communication infrastructures: Motivations, requirements, and challenges. *IEEE Communications Surveys & Tutorials*, 15(1), 5–20.